

Printed Name: \_\_\_\_\_

Section:             1 (8AM)             2 (9AM)

Problem 1	/ 22
Problem 2	/ 18
Problem 3	/ 20
Bonus	
<b>Total</b>	<b>/ 60</b>

## PHYSICS 221 EXAM 2

October 15, 2008

**Do not open this booklet until instructed. The exam will end promptly at 50 minutes after the hour.**

**Instructions:** When you are told to begin, check that this examination booklet contains all the numbered pages from 2 through 5. The Bonus Question is extra credit, and is optional.

Read each problem carefully so that you are certain what it is asking. Do not panic or be discouraged if you cannot do every part of every problem. If a part of a problem depends on a previous answer you have not obtained, define a symbol for it and proceed to maximize your credit. Keep moving to finish as much as you can!

**You must show your work.** The purpose of this exam is to show how well you understood the material we have covered. You must include an adequate explanation, including correct equations where applicable, for full credit. A number with no explanation will not get credit. **Show your answer's units**, and give an adequate number of significant digits. Completely numerical solutions showing no equations are not eligible for partial credit. Do not use scratch paper. Indicate any work on the backs of the pages that you wish to be considered.

**Box your answers.**

This examination is administered under the Cadet Honor Code. All suspected violations must be reported appropriately. The seat next to you must be unoccupied. No talking is permitted during the examination, apart from questions to the instructor. You may use a scientific calculator, but may not use "advanced features", including graphing, solving, derivatives, integrals, symbolic manipulation, or equation storage capabilities. Any other electronic devices, including headphones, cell phones, PDAs, and MP3 players, may not be used during the exam in any way. You may use the equation sheet distributed with the exam. No other notes or textbooks may be open during the exam.

**Problem 1: [22pt]** Two blocks of mass  $m_1 = 7.2$  kg and  $m_2 = 16.8$  kg are connected by a rope of negligible mass, and are being dragged by a horizontal force  $\vec{F}$ . The coefficient of kinetic friction between each block and the surface is  $\mu = 0.286$ .

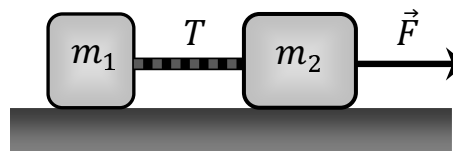

**(a) [4pt]** Draw a free body diagram for each block, showing and labeling all forces acting on the block.

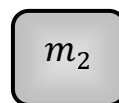
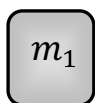

**(b) [6pt]** Write Newton's Law for the horizontal motion of each block. You should show two equations labeled to match your figure in part (a). Don't try to solve them yet.

**(c) [6pt]** Determine the acceleration of the system if  $F = 108$  N.

**(d) [6pt]** Find the tension  $T$  in the rope in this case.

**Problem 2: [18pt]** A roller coaster car of mass 500 kg including passengers travels on a track as shown. The radius of curvature of the track at point  $A$  is 10.0 m, and the radius of curvature of the track at point  $B$  is 15.0 m. Neglect friction.

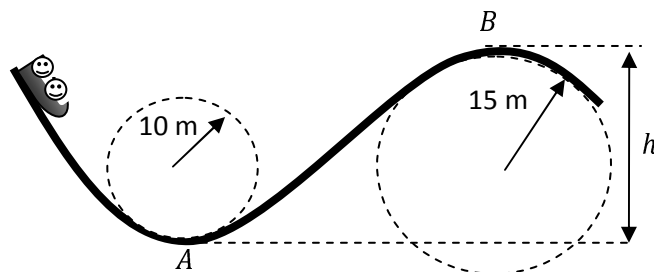

- (a) [6pt] If the car has a speed of 20.0 m/s at point  $A$ , what is the force of the track on the car at this point?
- (b) [6pt] What is the maximum speed the car can have at point  $B$  for the passengers to remain in their seats without the help of their seat belts?
- (c) [6pt] If the car reaches point  $B$  at the speed found in part (b), how high is point  $B$  above point  $A$ ? Find the distance  $h$  marked next to the figure. [If you don't have an answer to part (b), you can solve this assuming the speed at point  $B$  is 10 m/s.]

**Problem 3: [20pt]** A crate of mass 10.0 kg is pulled up a rough incline of length 15.0 m, beginning at rest. The pulling force  $\vec{F}_p$  has a magnitude of 99.0 N, directed parallel to the incline as shown. The coefficient of kinetic friction is  $\mu = 0.400$ . When answering the following questions, be careful to **include correct signs**.

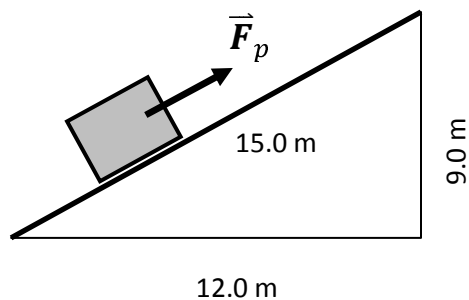

- (a) [4pt] How much work is done by  $\vec{F}_p$  on the crate?
- (b) [4pt] How much work is done by gravity on the crate?
- (c) [6pt] How much work is done by friction on the crate?

**(d) [6pt]** How fast is the crate moving at the top of the ramp?

---

The following problem is extra credit, and can increase your score by a maximum of 3 points. You cannot get more than 60 points on this exam via extra credit, however.

**Bonus Question: [3pt]** A stone is launched into the air. In addition to the force of gravity, it is subject to air resistance. Taking this into account, the time the stone takes to reach the top of its path is

- (a) greater than
- (b) less than
- (c) the same as

the time it takes to fall from the top of its trajectory to its original position.

Circle your answer [1pt] and explain it briefly [2pt].